

AMERICAN FORK

2011 STEEL DAYS

July 5 – 9, 2011

SOAP BOX DERBY

July 5, 2011

6:30 pm

Race down the Center Street hill starting at the Fitness Center
Information packet at www.afcity.org "Steel Days 2011"
or the American Fork Fitness Center.



Large, small, fancy, or plain.

You build your car and the memories you will gain!



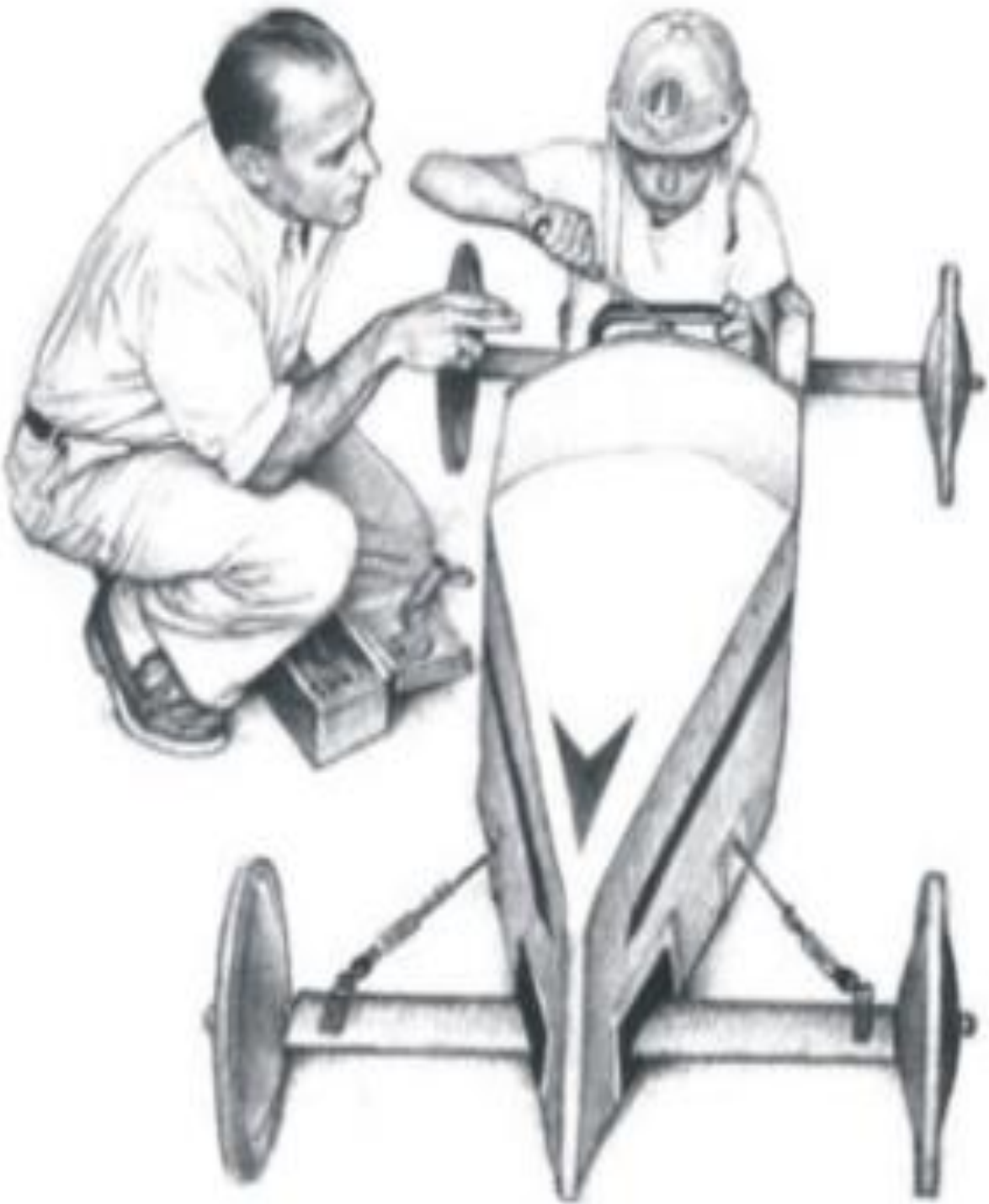

Norman
Rambowell



Presents the first annual Steel Days Soap Box Derby at Center Street

Eligibility and Registration

The American Fork Steel Days Soap Box Derby is open to anyone, male or female, over the age of 8. Non-residents of American Fork are welcome to participate. Participants must be registered by June 27th.

You can register at the American Fork Fitness Center. Registration fee is \$10 per driver. Requested numbers for you vehicle will be granted on a first-come first-served basis.

A single car may compete in multiple classes (in the case of a family with children of different ages, for example) provided it meets the weight requirements for the class in which it is competing. Each car may have only one driver per class. If two people of the same age group want to compete in one car, the oldest will be bumped to the next class up.

Competitors are divided into classes according to age on the date of the race: Stock class: 8-12 years; Super Stock class: 13-17 years; Open Class: 18 years and older.

Spirit of Fair Competition

The objective of this event is to provide fun for everyone regardless of resources. To that end the rules strive to provide maximum safety and fair competition with the fewest requirements possible.

As issues arise that are not specifically addressed in the rules, the racing committee will pass judgment to maintain the spirit of the rules. If you have a question about whether something is appropriate, *ask*. A phone call now could prevent a disqualification at inspection time. As clarifications are made they will be applied universally to all participants.

General Information

The Race will be held Tuesday, July 5th, 2011 at 6:30 pm, just west of AF Fitness Center (454 North Center Street). Inspection of each vehicle must take place one week prior to the race. No entries will be accepted after June 28th 2011. (All ballast must be bolted or otherwise securely fastened.)

Racers are to be completely gravity powered. No starting or propulsion devices of any kind are allowed. Driver must be in a seated position. No head-first configurations are allowed. Reclining to any degree is an acceptable configuration as long as driver visibility is not impaired.

For more information, call A.F. Recreation at 801-763-3080

Some hints and guidelines for building soap box derby cars are available on the internet. Tips and links are available at the afcity.net/recreation. Be aware, however, that this event is in no way affiliated with The All-American Soap Box Derby and rules and specifications for those events do not necessarily apply.

Sponsors are allowed and company names, logos, etc. may be displayed on the cars.

Any questions, comments, or requests for clarification should be directed to Randy Spafford at 310-5311 or e-mail at rspafford@afcity.net.

Safety

All drivers must wear an approved helmet (DOT, Snell, etc.). No part of the driver may project outside of the body of the car. Car must have a completely enclosed floor. The vehicle must not have any sharp projections, loose parts or edges that might pose a safety hazard. All ballast must be securely fastened and cannot move, accidentally or with driver intervention, during the race. Anything inside the cockpit that could injure the driver in the event of a crash should be padded.

In order to maintain the safety of the event the race committee may impose additional requirements as conditions warrant.

General Vehicle Specifications for Stock and Super Stock Categories

	Minimum	Maximum
Track width (outside of tires)*	24 inches	36 inches
Vehicle height	3" ground clearance	72 inches
Total vehicle length	72 inches	96 inches
Wheelbase	48 inches	72 inches
Vehicle Weight		
Stock (8-12 yrs)	- none -	275 lbs. with driver
Super Stock (13-17 yrs)	- none -	340 lbs. with driver
Open Class (18+ yrs)	- none -	400 lbs. with driver

* Frames may be made of any material. Any metal frame elements that extend beyond the wheels must be properly blunted with a cross bar to prevent piercing in the event of a crash. Sheet metal on the body is okay. Axles and components may be steel. Road clearance must be no less than 3". The ends of the car must be up 20° degrees from the wheels to clear the ramp. The furthest forward point of the car must be no higher than 12" so the starting gate will contact. Car must have 4 wheels and all four wheels must be in contact with the track at all times. (All ballast must be bolted or otherwise securely fastened.)

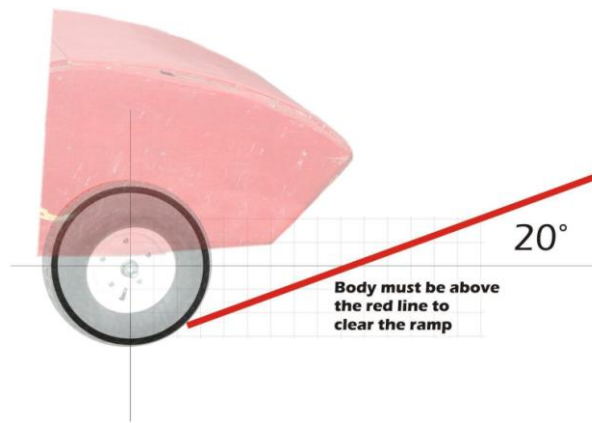

All weight must be bolted or otherwise securely attached. No loose ballast is permitted.

All Cars must have Brakes

All vehicles must be equipped with adequate brakes. Braking tests will be conducted at the inspection on June 28th at 5:30pm to ensure that they are adequate. Cars without adequate brakes will not be allowed to race. Hand brakes are discouraged. Consideration will be made for those with physical disabilities.

Steering

Steering must be positively controlled. Driver must be able to steer with one hand if necessary.

No rope pull steering is allowed. Foot steering is not allowed. Cable wind steering (a cable is wrapped around a cylinder that pulls on the axle as the shaft is turned) is recommended as an easy way to positively steer. Tiller steering is discouraged, especially if the car is equipped with a hand brake.

See attached detail for information on steering

Wheels

If you wish to race your car in other soap box derbies in Utah County, you must choose a wheel that meets the spec requirements for those races.

This is a spec wheel for other races.

Wheels are 13" diameter pneumatic tires with integral bearings, Harbor Freight no. 36054-0VGA..

Wheels fit on a 5/8" axle. A 5/8" bolt 4-1/2" long is just the right size to go through the hub. Wheels must have some sort of locking arrangement on the nut such as a locknut or an additional nut.

Wheels may be trued, balanced, etc, but no material may be removed from the wheels other than that necessary to balance. Wheels may be lubricated, but no modifications to the bearings are allowed.

Inspections.

A preliminary inspection will be held at 5:30 pm Tuesday, June 28th, 2011 in the parking lot by the Philly field south of the Cemetery. The purpose of this inspection is to give the participants time to

apply any modifications that may be required. Helmets will also be inspected. No one will be allowed to race with a helmet that is not Snell or DOT approved. Bicycle helmets are not allowed. .

Final inspection will be performed on race day. Winning cars in each heat may be inspected after the heat to ensure that they conform to the rules.

Race procedures

Drivers must keep hands and arms inside the body at all times. Any actions that appear to be pushing or propelling the car could result in disqualification from the heat. Any car that leaves its lane during the race may be subject to disqualification. Crowding or other unsportsmanlike driving is not allowed.

Racing will be double elimination in heats of 2 cars each with 3 places being awarded in each class. In addition, a People's Choice Award will be given to the car that the spectators vote as their favorite.

The format of the race may change as conditions and participation warrant.

Parade and Car Show

Racers are invited to participate in the parade on Saturday. More details will come forth later.

At the end of the parade we set up the cars in the Rotary Park for display during the festivities. Your car doesn't have to be in the parade to display it at the car show.

We want to help you get started and remove the fear of mechanics ...so ...we have purchased a few Go Kart Kits called, GOKITS. The kit has a steering mechanism and wheels. All you build is the body and the break. You can order them from us for \$90 each. Please ask one of the recreation coordinators at the fitness center for more information.

Also... If you take a copy of your paid registration form to "Harbor Freight" in Orem next to Staples on State Street, you can purchase tires for a discount rate. You must show the manager the registration form.

Here are some other web sites that may help you in your quest.

Waycoolkits.com

Derby.gokit.com

All American soapbox derby.com

Start building your memories now!

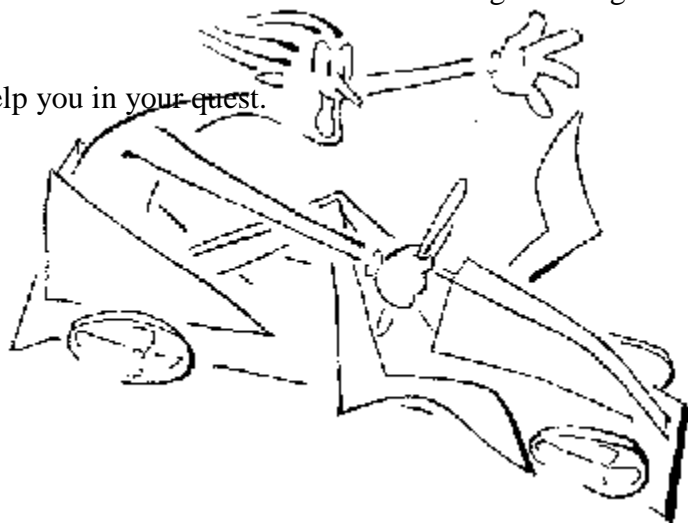



Steel Days Soap Box Derby Registration Form

Name _____ Preferred Car Number* _____

Address _____

Phone _____ e-mail _____

**Numbers will be granted on a first-come first-served basis*

Drivers

Please list below the name of each participant under the class he/she will be racing in. Entry fee is \$10 per driver.

Waiver and Release of Liability

The undersigned does hereby release, waive, and forever discharge American Fork City of, its assigns, employees, agents or representatives from and against any and all liability for any harm, injury, damage, causes of action or costs and expenses of any nature for which Participant may have or which may hereafter accrue to the Participant, arising out of or related to any loss, damage, or injury, that may be sustained by Participant in conjunction with Participant's involvement in this activity.

Racing involves in inherent risks that may include death or injury. Participant has signed this Release in full recognition and appreciation of the dangers, hazards and risks involved with the Activity.

Participant certifies that she/he is physically fit and in good health and has not been advised otherwise by any qualified medical personnel. Participant is not aware of any health-related reasons or problems, which would preclude or restrict Participant's ability to take part in the Activity.

<u>Driver Name</u>	<u>Signature</u>	<u>Age</u>	<u>Guardian's Signature</u>
_____	_____	_____	_____
_____	_____	_____	_____
_____	_____	_____	_____

Return completed forms and fee to the American Fork Fitness Center (454 North Center Street)

For more information, call A.F. Recreation at 801-763-3080

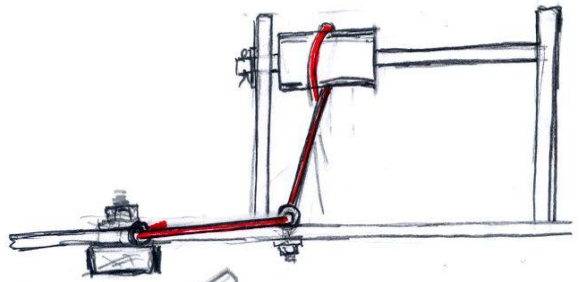
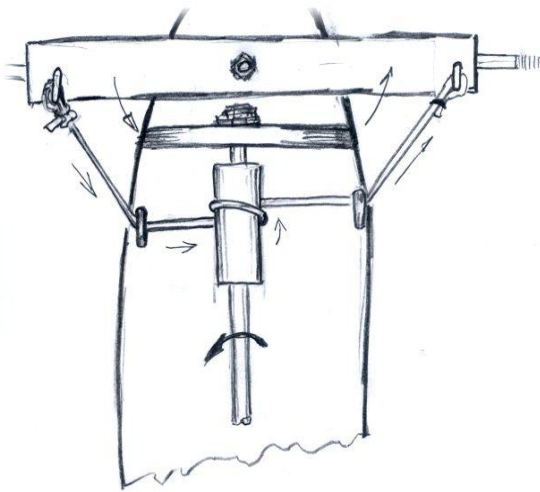

Recommended Steering Design

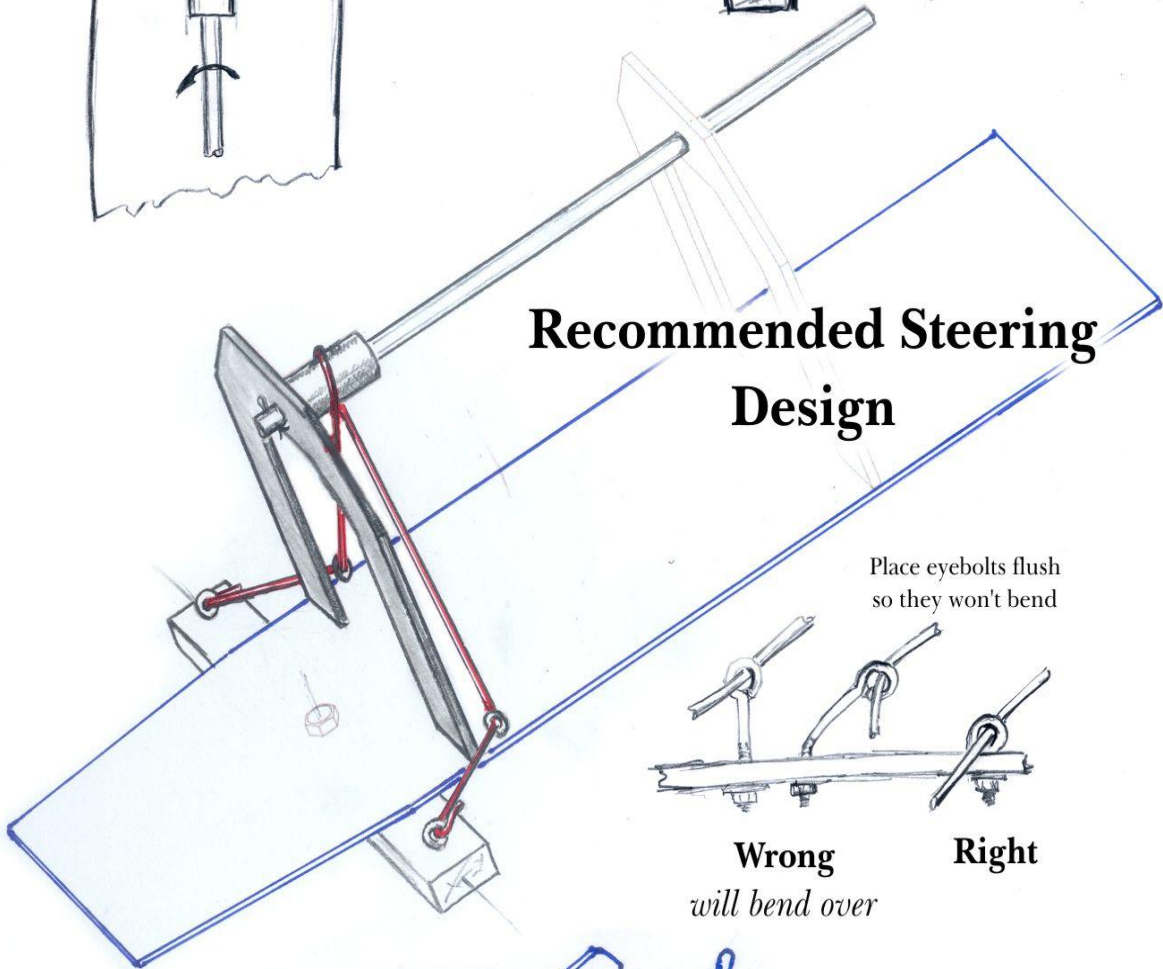

Place eyebolts flush so they won't bend

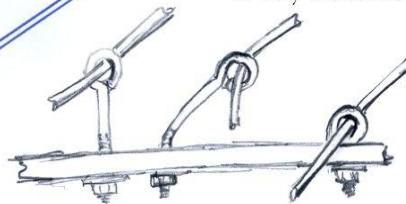

Wrong
will bend over

Right

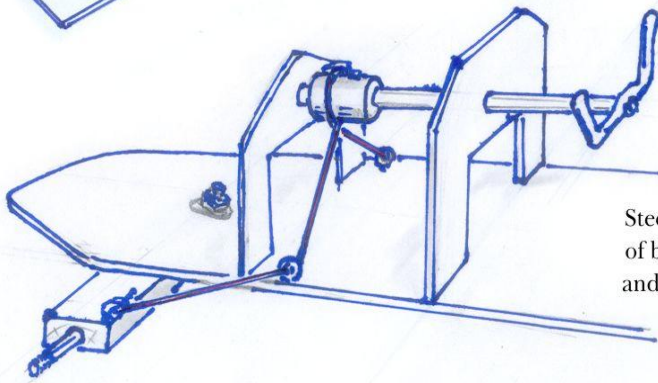

Steering wheel can be made of bicycle handlebars cut off and mounted perpendicular to the shaft.

American Fork City Box Car Derby

Derby Car Inspection

Car Number

- 1. Steering, turning radius <15' _____
- 2. Brakes, hold on the ramp _____
- 3. Body fully enclosed, seat ht. <16" _____
- 4. No starting devices _____
- 5. No sharp edges, protrusions, etc. _____
- 6. Wheels positively secured _____
- 7. Approved helmet _____
- 8. Other _____

Weight	_____ Stock	Age (8-12)	Includes Driver Weight (275 max)
	_____ Super Stock	Age (13-17)	Weight (340 max)
	_____ Open Division	18 and up	Weight (400 max)

Inspected by: _____ Date: _____